



Installation manual



1. Assembly and installation of the catch basin

- 1.1 Preliminary assembly
- 1.2 Order of the components installation
- 1.3 Installation of the cast-iron head T-102
- 1.4 Installation of the B-102 and CC-102 set
- 1.5 Compacting of the granular embankment
- 1.6 Total compacting of the granular
- 1.7 Installation of the CA-102
- 1.8 Installation and compacting of the paving with the CA-102 and G-102
- 1.9 Use of the CA-102
- 1.10 How to raise a CA-102-40mm with a CA-102-50mm or CA-102-60mm
- 1.11 Final installation /diagrammatic section
- 1.12 Rehabilitation stages of a catch basin

1.1 Preliminary assembly

Fig. 1.1.1



- ▶ Insert the sleeve-guard on the catchment frame until the two parts are hooked together (see Fig. 1.1.1).
- ▶ The set is now pre-assembled (see Fig. 1.1.2).



Fig. 1.1.2

1.2 Order of the components installation

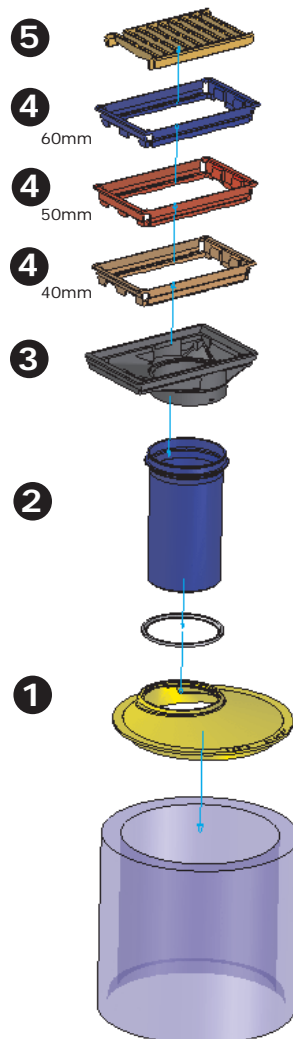

Components	
5	Grate
4	Adapter
3	Catchment frame
2	Sleeve-guard
1	Head

Fig. 1.2.1

1.3 Installation of the cast-iron head T-102 (First component - On concrete base)

The T-102 component is installed directly on the concrete base (see Fig. 1.3.1).

By rotation of the T-102, the alignment of the futur G-102 grate is assured (see Fig 1.3.2).

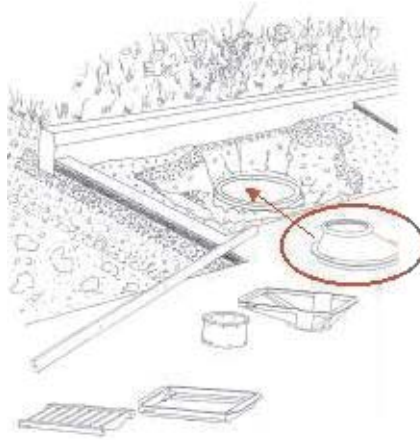

Fig. 1.3.1

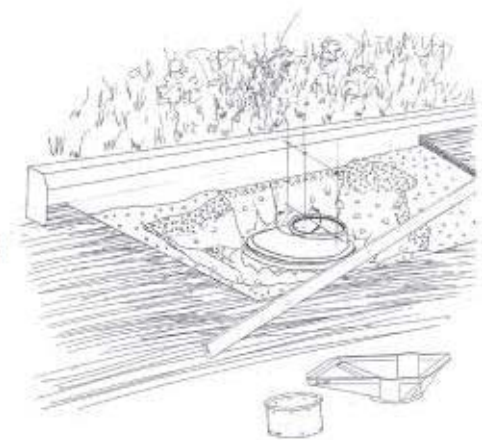

Fig. 1.3.2

1.4 Installation of the B-102 and CC-102 set (Second component - On T-102)

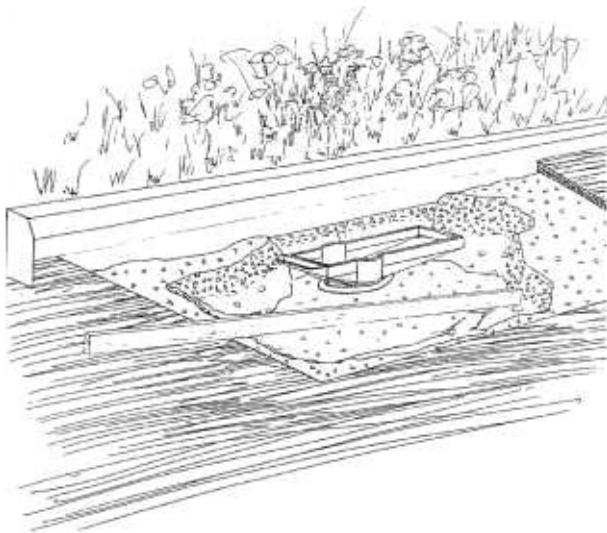

Fig. 1.4.1

➤ Insert the sleeve-guard in the head.

1.5 Compacting of the granular embankment

Proceed to the compacting stages. ◀

Withdraw the grate from the catchment frame. ◀

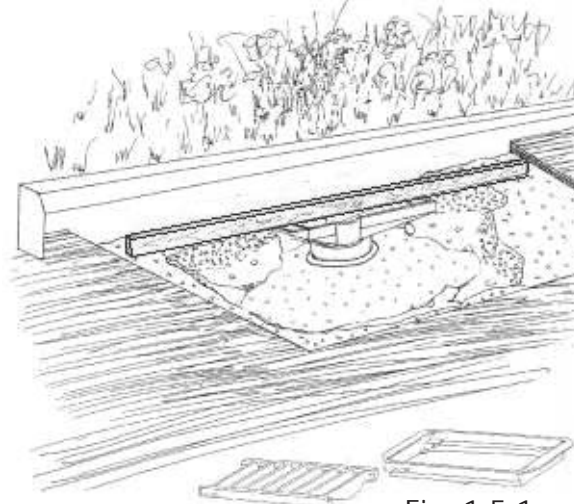



Fig. 1.5.1

1.6 Compacting of the granular (G-102)

View showing the completed installation of the catchment's frame after compacting the granular embankment. 

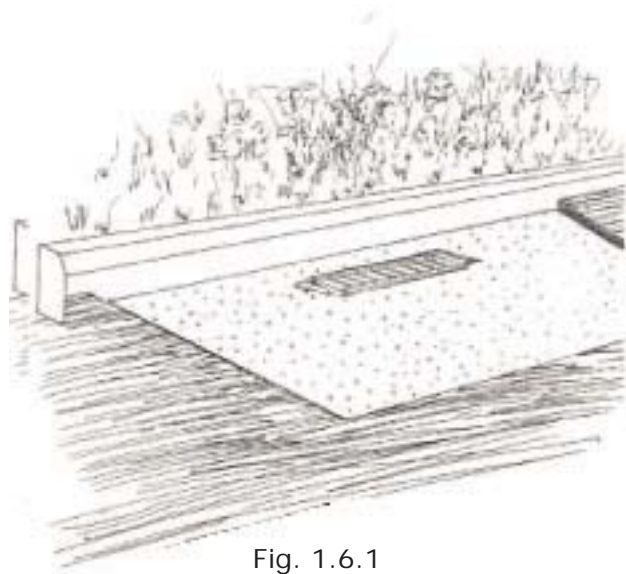

Fig. 1.6.1

1.7 Installation of the CA-102 (Adapter - see figure 1.2.1)

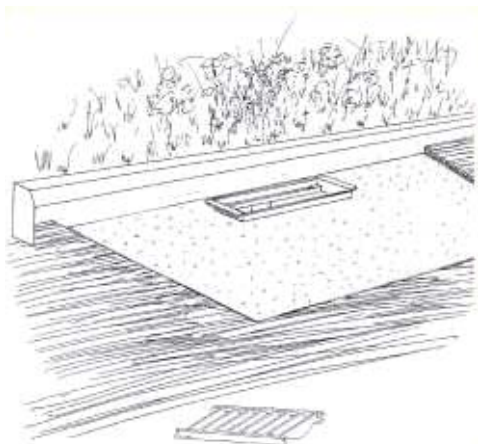







Fig. 1.7.1

-  Take out the G-102 grate.
-  Clean the interior of the catchment's frame.
-  Install the CA-102 (40,50 or 60mm according to the thickness of the paving).
-  Install the G-102 grate in the adapter.

NOTE: To avoid that the granular embankment falls in the catchment basin, we suggest using a geo-textile to wrap the grate.

1.8 Installing and compacting the paving (With CA-102 and G-102)

View showing the completed installation after laying the paving. 

Proceed paving using a steam roller around and on the GRATE, to obtain a constant and uniform level of paving. 

Withdraw the GRATE and the geo-textile membrane and put the GRATE back in place to complete the operation. 

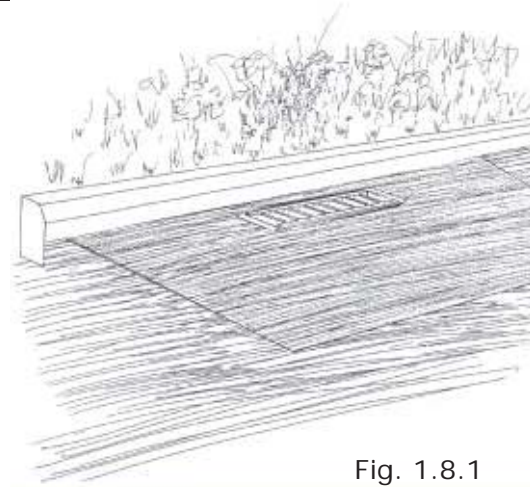

Fig. 1.8.1

1.9 Use of the CA-102

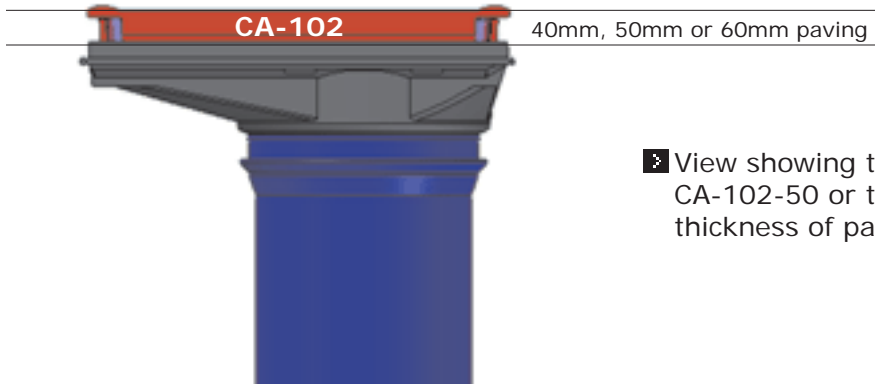

Fig. 1.9.1

- View showing the choice between the CA-102-40 or the CA-102-50 or the CA-102-60, according to the required thickness of paving.

1.10 How to raise a CA-102-40 with a CA-102-50 or CA-102-60

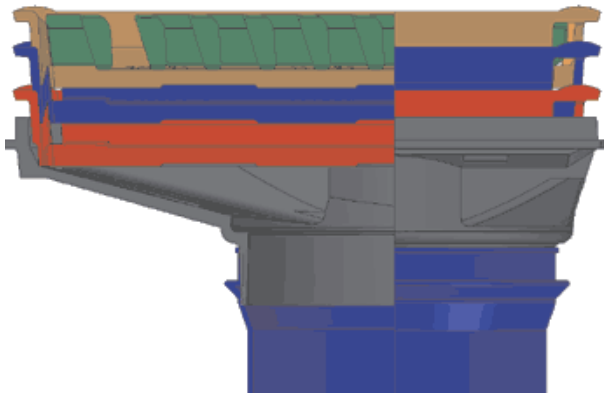

Fig. 1.10.1

- Take out the grate.
- Insert the CA-102-50 or CA-102-60 on the CA-102-40 (or vice-versa).
- Replace the grate.
- Lay the asphalt.
- With a steamroller, compact the paving.

1.11 Final installation (diagrammatic section)

Notice the preferential direction of the grate, <<

Notice also the orientation of the CC-102 catchment's frame with its' prominent part towards the top of the slope. <<

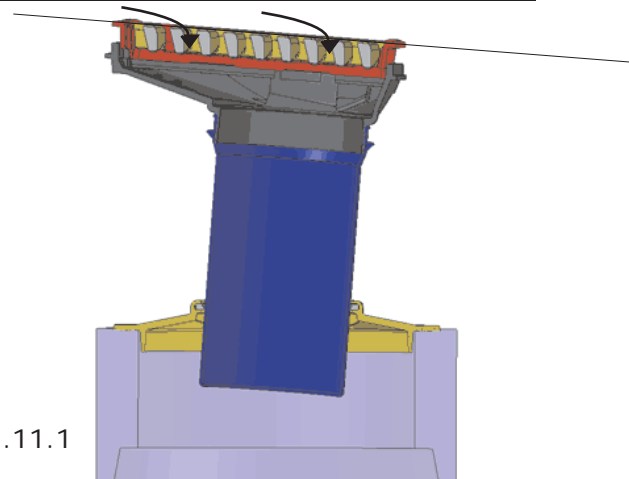
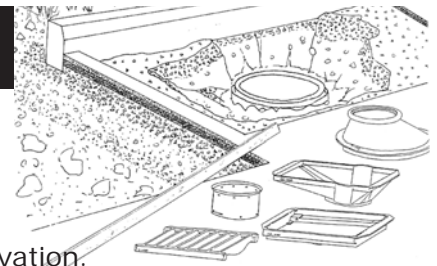

Fig. 1.11.1

1.12 Rehabilitation stages of a catch basin



- Arrange the components of the Puistar system set close to the excavation.
- Proceed to cut the paving of the area to rehabilitate.
- Excavate the granular materials until the superior part of the concrete tank.
- Break up the existing concrete components and other accessories (frame, grate, concrete head, concrete extension) so as to clear the top of the concrete tank.
- Make sure that the structure of the concrete tank is safe, stable and that the valve is in place.
- Take out the concrete lip of the tank, with the help of a skil saw for concrete.
- Install a watertight washer (butyl) on the perimeter of the concrete tank. (optional)
- Put the cast-iron head on the concrete tank.
- By rotation of the cast-iron head on the concrete tank, position the circular opening to 14 inches (with the help of a vertical level and a measuring tape) in accordance with the required distance (according to the required norms) between the GRATE and the concrete border or sidewalk. Cover the washer between the cast-iron HEAD and the tank with a geo-textile membrane.
- Assemble previously the SLEEVE-GUARD on the CATCHMENT FRAME (fasten together well).
- Insert the SLEEVE-GUARD in the opening of the cast-iron HEAD (a minimum of 4 inches is to be maintained in the interior of the HEAD). The lip of the CATCHMENT FRAME must always be directed towards the top of the slope. Hold out a line between the two extremities of the excavation to assure that the angle of the CATCHMENT FRAME adopts the profile of the street.
- Complete the installation of the CATCHMENT FRAME by compacting it in stages to its' final level while respecting the profile of the slope of the street (wrap the GRATE in a geo-textile membrane and put it in the CATCHMENT FRAME to maximise the support surface) by using a vibrating plate and /or a steamroller to compact the materials of granular embankment under the CATCHMENT FRAME . Proceed to the stages of compacting the granular embankment in conformity with the required norms and according to rules of the art , until the final stage of granular embankment.
- Withdraw the GRATE from the CATCHMENT FRAME, insert the ADAPTER in the CATCHMENT FRAME (in expectation of the future paving) and put the GRATE (wrapped in a geo-textile membrane) in the CATCHMENT FRAME.
- Proceed to paving using the steamroller around and on the GRATE, to obtain a constant and uniform paving.
- Withdraw the GRATE and the geo-textile membrane and put the GRATE back in place to complete the operation.